

Installation, Operation and Maintenance

**V SERIES
Wallmount Air Conditioners
R410A Series**



Your equipment is covered by a LIMITED WARRANTY against defects in material and workmanship.

This is a vertical, wallmount unit designed for many different applications in both residential and commercial settings. It is self-contained and arrives completely assembled, factory-charged and wired. The unit is 100% run-tested at the factory to ensure proper operation. Your unit is supplied with high-quality copper tubing and enhanced aluminum-finned coils for high heat transfer efficiency and long life. The unit cabinet is constructed of G-90 galvanized steel. All exterior surfaces are finished with a baked-on polyester coating. This will provide excellent corrosion protection in most applications. However, if the unit is installed in an area with a corrosive atmosphere, such as near an industrial plant or on the seacoast, additional coating should be considered to extend the life of the coils and cabinet.

This unit was designed for up to 105°F of ambient temperature.

INSPECTION AND UNPACKING

A thorough inspection of the shipping container should be made immediately upon receiving your unit. Look for any punctures or openings. If it appears as if damage has occurred, it should be noted on the freight bill before signing. The delivering carrier should be contacted immediately to inspect damage, and no installation work should begin until this inspection is completed.



DANGER: BEFORE PERFORMING ANY WORK ON THIS EQUIPMENT, POWER SUPPLY MUST BE TURNED OFF AT THE HOUSEHOLD SERVICE BOX TO AVOID THE POSSIBILITY OF SHOCK, INJURY, DEATH OR DAMAGE TO EQUIPMENT.

SAFETY RULES



WARNING: FAILURE TO FOLLOW THESE RULES AND INSTRUCTIONS COULD CAUSE A MAL-FUNCTION OR DESTRUCTION OF THE EQUIPMENT WHICH COULD RESULT IN PROPERTY DAMAGE, SERIOUS BODILY INJURY, OR DEATH.

1. Installation and repair **MUST** be done by a qualified person. The equipment should be inspected before use and at least once annually by a professional service person.
2. **AVOID ELECTRICAL SHOCK!** Turn power OFF when servicing. There may be more than one disconnect switch to de-energize unit.
3. Close cover(s) before returning breaker(s) to “ON” position.
4. Please observe good safety practices by wearing personal protective equipment such as gloves and safety glasses to avoid injury.
5. Installation **MUST** conform to local codes. In the absence of local codes, refer to the National Electrical Code (NEC), ANS/NFPA No. 70-1993 and recommendations made by the National Board of Fire Underwriters.

In our continuing effort to improve our product, specifications may change without notice. If there are any questions, please see the contact information on the last page of this manual.

In all cases, the equipment **MUST** be installed in accordance with the installation instructions described in this manual.



WARNING: IMPROPER INSTALLATION MAY DAMAGE EQUIPMENT, CAN CREATE A HAZARD, AND WILL VOID THE WARRANTY.

OPERATING INSTRUCTIONS

If heating and cooling functions are controlled by separate thermostats, turn the furnace thermostat to the “OFF” position during the cooling season to prevent simultaneous operation of the heating and cooling systems. Reverse the procedure during the heating season.

If the same thermostat controls both heating and cooling functions, set the thermostat to either HEAT or COOL as desired.

Set the desired temperature on your thermostat dial and set the fan switch to “ON” (for continuous air circulation) or to “AUTOMATIC” (for air circulation only when the air conditioning system is operating).

IMPORTANT: Wait at least three (3) minutes after turning the air conditioner off before trying to restart. If an attempt is made to start the compressor before the refrigerant pressures are equalized, the compressor motor may trip on its overload. An additional waiting period will be required before restarting.

MAINTENANCE

1. Always install and keep filters clean. Check filters every 2 weeks. Clean or replace if necessary. The factory-installed filter is located behind the center front access panel.

TO CHANGE SYSTEM FILTER:

- A. Turn the power to the unit off at the unit disconnect. The disconnect is located on the front of the V Series unit behind a small access door.
- B. Remove the front center access door from the unit.
- C. Remove and replace the filters with the type and size indicated in the table below.
- D. Replace the access door and turn on the power to the unit.

NOTE: If your system has a filter grille installed in the return air opening, the unit filter should have been discarded during installation.

The filter installed into the return air grille assembly should be replaced with the same size and type provided with the grille.

If your system is equipped with a fresh air intake, the filter for the fresh air assembly is accessed through the front center panel. The filter is a permanent washable type.

UNIT MODEL	QTY.	FILTER SIZE	TYPE
18, 24, 30, 36	1	16 x 25 x 1 (standard)	Disposable
18, 24, 30, 36	1	16 x 25 x 2 (optional)	Disposable
48, 60	1	20 x 30 x 1 (standard)	Disposable
48, 60	1	20 x 30 x 2 (optional)	Disposable



WARNING: SERIOUS INJURY MAY RESULT IF WATER SPRAY IS DIRECTED TOWARD LIVE ELECTRICAL CONNECTIONS OR POWER SOURCES.

TO CLEAN FRESH AIR INTAKE FILTER:

- A. Follow steps A and B at left "TO CHANGE SYSTEM FILTER".
- B. Gently pull out the filter from the bottom.
- C. Wash the filter with water.
- D. Reinstall the filter, by sliding it into the retaining rail.
- E. Replace the access door and turn the power on to the unit.

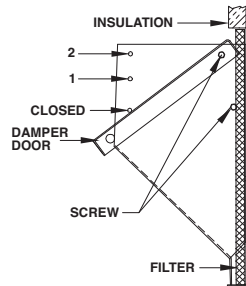

2. Keep the outdoor coil clean. Wash it down with a garden hose if necessary. **BE SURE THE UNIT DISCONNECT IS IN THE "OFF" POSITION AND THAT ALL ELECTRICAL POWER TO THE UNIT IS TURNED OFF BEFORE CLEANING THE SYSTEM.**

Remove any loose grass, leaves, papers, etc., from the area around the condenser coil. These could reduce the air supply through the coil and reduce the amount of cooling capacity.

3. Since the air conditioner is located outdoors, it is exposed to all weather elements. Treat it with a good automobile paste wax twice a year (in the spring and fall).

Check with your contractor if you have any questions regarding the maintenance or operation of your unit.

INSTALLATION

A. CODES

The installer SHALL comply with all local, state, and federal codes and/or regulations pertaining to this type of equipment and its installation. Such codes and/or regulations should take precedence over any recommendations contained herein in lieu of local codes. Installations SHALL be made in accordance with the National Electrical Code, local codes, and recommendations made by the National Board of Fire Underwriters.

B. UNIT SITE LOCATION

1. To eliminate noise from being transmitted into noise-sensitive areas, the unit should **NOT** be installed on walls adjoining bedrooms, sleeping quarters, or adjacent to windows.
2. Locating the unit as close as possible to the main duct system or area to be conditioned, will prevent lengthy duct runs and unnecessary thermal and air-pressure losses.
3. The clearance to combustibles is 0" on all sides, and 1/4" for the first three (3) feet of supply duct.
4. The condenser air inlets (left, right and bottom inlets) SHALL be located at least 12" away from walls or other obstructions for unrestricted airflow.
5. The condenser air outlet should be located at least 6' away from any obstructions to prevent recirculation of condenser air.

6. Service clearance is 28" from the electrical box access panel located on the front of the unit and 28" from the center, upper, and lower front access panels.
7. The wall selected for unit installation **MUST** be able to or be made to safely support the weight of the unit.
8. Do **NOT** locate where heat, lint or exhaust fumes will be discharged on the unit (as from dryer vents).

C. UNIT PREPARATION

1. The V Series model units have top rain flashing built onto the unit. The bottom-mounting flange for all models is shipped separately and in place. (Refer to "Section J. Unit Installation" for the recommended use of the bottom flange.)
2. Electrical entrances are located on the right side, left side, and back of all V Series units. Refer to "Section H. Electrical Hook-up" for details.
3. Bend the lids of return and supply opening to form a return and supply air collars and install air gaskets.
4. The supply and return air ducts should be checked to be sure they:
 - a. Match the openings on the unit to be installed.
 - b. Have the same distance between them vertically as the openings on the unit to be installed.
5. If the factory-installed filter is used on your installation, access to the filter is made through the center panel on the front of the unit. **IF A REMOTE FILTER IS USED, SUCH AS A FILTER GRILLE, THE FACTORY-INSTALLED FILTER MUST BE REMOVED AND DISCARDED.**

D. DUCTWORK

1. Properly-sized duct systems are critical for satisfactory operation of any air conditioning system. All ductwork **MUST** be correctly sized for the design air flow requirement of the equipment.
2. The recommended operation duct static is to deduct 0.07" W.C. for any size of heater 5 kW to 20 kW on factory- or field-installed heaters.
3. Ductwork routed through wall cavities, as well as any duct not in conditioned space, **MUST** be insulated. Supply ducting routed through exterior walls **MUST** be insulated with 1" insulation to the back of the unit.
4. Supply and return air ducts should be flush with the exterior wall and sized to fit over the unit duct collars in order to compress the collar air gasket.
5. If supply duct is flashed to the exterior of a building constructed with combustible material, the flashing **MUST** be insulated in order to maintain the required clearances to combustible materials. Required clearance is 1/4" for the first three (3) feet of supply duct.

E. FILTERS

1. One-inch disposable filters are supplied standard in each unit. Two-inch disposable filters can also be used and are available as an option. The filter rack is adjustable to accommodate 2" filters. The filter rack on this series is adapted by bending the retaining brackets. Refer to the Maintenance section for the procedures for changing the filters.
2. If a filter grille is used in the installation, the filter should be properly sized to allow a maximum velocity of 400 FPM. **THE FACTORY-INSTALLED FILTER MUST BE REMOVED.**

F. ELECTRICAL POWER

The installer **MUST** check available power to make certain it matches the unit nameplate rating and that constant voltage can be maintained to the unit. Unsatisfactory and unsafe performance could otherwise result. The local power company should be contacted about questions concerning power supply.

G. BREAKER/DISCONNECT ASSEMBLY

These units are standard equipped from the factory with a unit disconnect. This is in the form of a circuit breaker (230V models) or a disconnect (460V models). If an optional electric heat kit is to be installed, follow the instructions included with the heater assembly. See Figure 1 for reference.

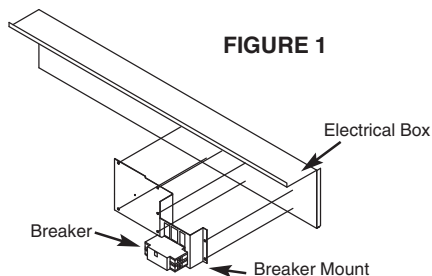

FIGURE 1



WARNING: ELECTRICAL EQUIPMENT SHOULD BE INSTALLED BY A QUALIFIED, LICENSED ELECTRICIAN. IMPROPER ELECTRICAL HOOK-UP MAY DAMAGE EQUIPMENT, CAN CREATE A HAZARD AND WILL VOID WARRANTY.

H. ELECTRICAL HOOK-UP

The line voltage electrical service can be routed through the right side panel, the right side of the back panel, or left side panel. Each area is supplied with two line voltage knock-outs (1/2" - 3/4" and 1" - 1 1/4"). Low voltage wiring can be routed through the right side panel.

NOTE: When routing line voltage through the return air compartment, conduit **MUST** be used (even though this is a dry area) to comply with the NEC code. A 1 1/4" PVC conduit is supplied for this application. Refer to the ELECTRICAL DATA tables for minimum wire size and maximum breaker size. All wire sizes listed under the dual-feed circuit column are based on no more than three (3) conductors in the same conduit. If two circuits or more than three (3) conductors are to be routed in the same conduit, the ampacity of the wire size listed **MUST** be derated. Refer to Article 310 of the NEC code for adjustment factors. Be sure to install a ground wire of the proper size to the unit's equipment ground lug.

I. LOW VOLTAGE WIRING

230 volt, 1- and 3-phase units are equipped with dual-primary voltage transformers for 208/240 volt operation. These models are factory wired to the 240 volt tap. For 208 volt operation connect the factory-installed black wires from the 240 volt tap to the 208 volt tap. The acceptable voltage range of the tap is as follows.

Tap	Voltage Range
240 Volt	253 - 216
208 Volt	220 - 187

Five (5) conductor thermostat wires should be run from the thermostat location to the unit. Thermostat wire should be sized as shown on the table below.

Wire Gauge	Maximum Length
20	45'
18	60'
16	100'
14	160'
12	250'

Refer to wiring diagrams for connection details.

STAGING OF ELECTRIC HEAT

All V Series units with electric heat assemblies above 10 kW may be wired for single- or two-stage heat. These models come factory wired for single-stage operation. For two-stage operation, remove the jumper bar from between the W2 and E terminal. Wire the first-stage heat to terminal W2. Wire the second-stage heat to terminal E.

J. UNIT INSTALLATION

V SERIES UNITS ARE FOR USE IN SINGLE-STORY BUILDINGS ONLY

- As previously stated, the wall that the unit is to be installed onto **MUST** be strong enough to support the unit under the condition for which it will be used. For example, a unit to be installed on a building that is intended to be transported will require more wall strength than a unit installed at a permanent site. Existing walls may need additional reinforcement. **NEVER RELY ON EXTERIOR SIDING OR PLYWOOD TO SUPPORT THE UNIT.** Figure 2 below represents a typical installation of a single-story stud wall at a permanent site. Since building materials and techniques vary with regions and intended use, a building contractor and/or local building code official **MUST** be consulted for suitable construction methods.
- Locate and attach the lower mounting bracket in the desired location on the building.
- Apply a suitable caulk across the entire length of the top rain flashing and side mounting flanges.
- Remove the flanges on both ends of the pallet and slide the unit approximately 2" off the rear of pallet. Lift unit gently into location with fork truck, taking care to align unit with lower mounting bracket.
- While allowing a small portion of weight on the lower bracket, push the unit against the wall and fasten appropriately. A 3/4" drain hose is located on the bottom side of the unit. The drain may be extended for condensate removal to comply with local codes (use fitting size or larger). Install a condensate trap on this line.

FIGURE 2

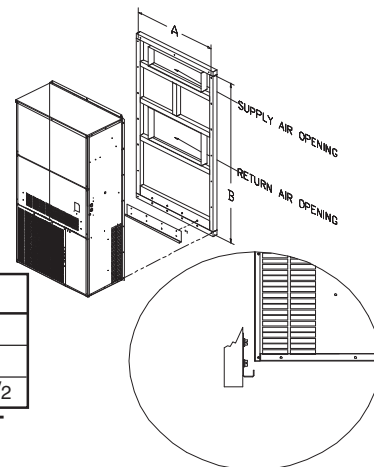

Unit Model	A	B
18/24	35	71
30/36	39	71
48/60	42	86 1/2

MOUNTING FLANGE BOLT PATTERN DIMENSIONS

K. CONDENSATE DRAIN

A3/4" drain hose is located on the bottom side of the unit. The drain may be extended for condensate removal to comply with local codes (use fitting size or larger). Install a condensate trap on this line.

L. ELECTRICAL HEAT INSTALLATION

Electric heat is an option on V Series units and can be field-installed on either single- or three-phase models.

Refer to the individual installation instructions for installing heater kits.

EXPLODED PARTS DRAWING — 18 / 24 / 30 / 36

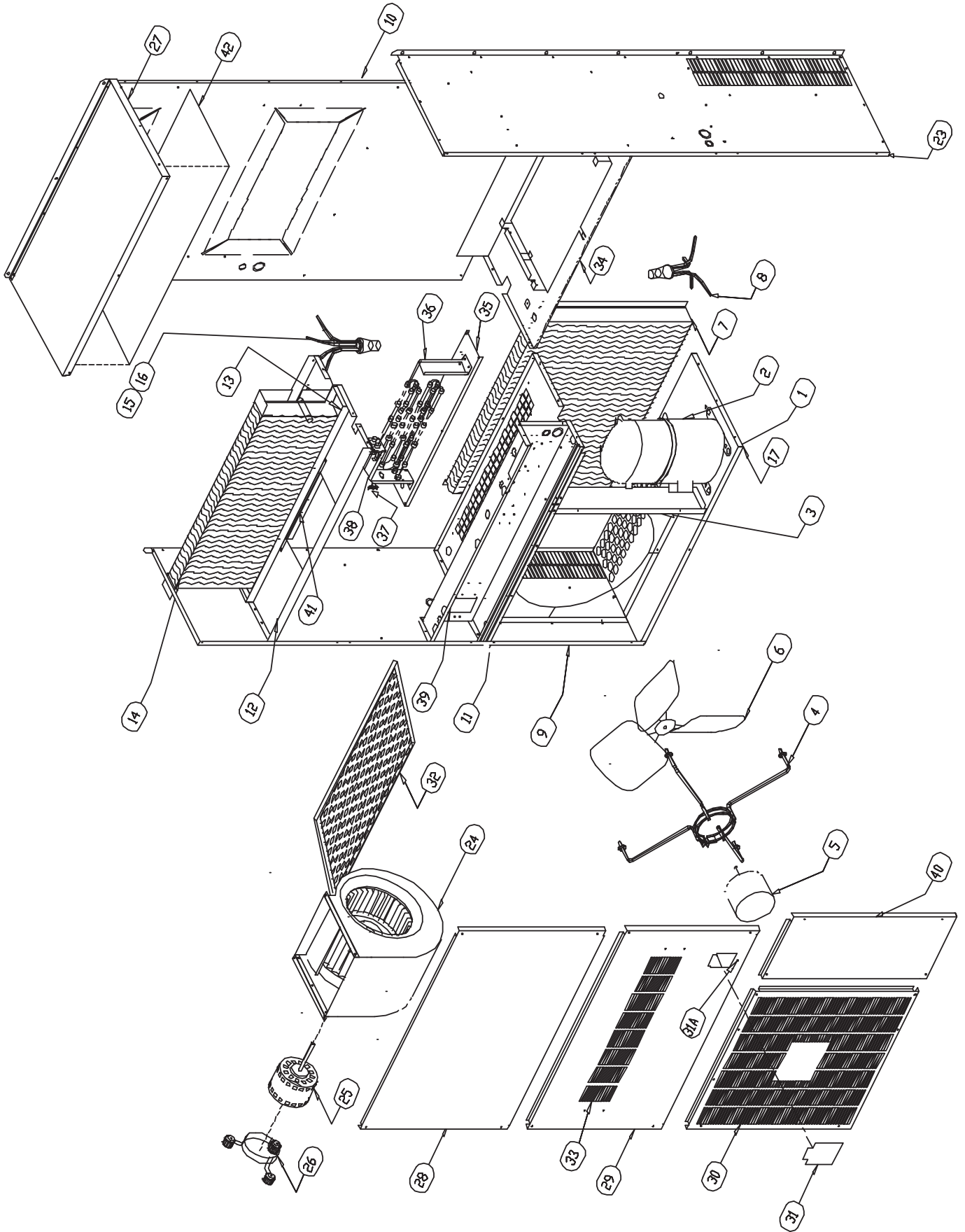

EXPLODED PARTS DRAWING — 48 / 60

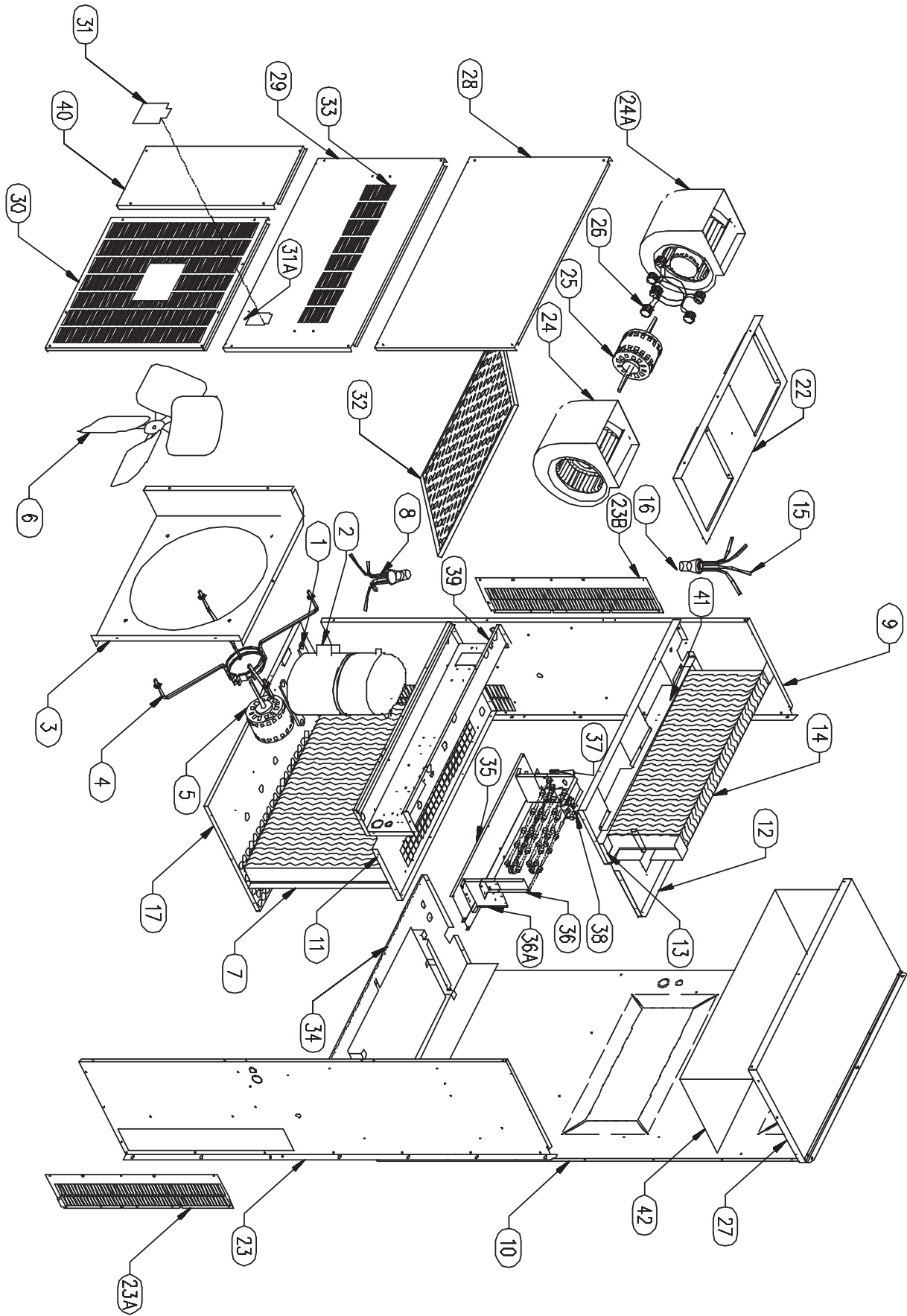

REPLACEMENT PARTS LIST - V SERIES WALLMOUNT A/C

	PART NUMBER	DESCRIPTION	V418B1	V424B1	V430B1	V430B3	V436B1	V436B3	V436B4	V448B1	V448B3	V448B4	V460B1	V460B3	V460B4
2	COMP-L18-001	H62J18BABCA													
2	COMP-L24-001	H82J24BABCA													
2	COMP-L30-001	H82J28BABCA													
2	COMP-L36-001	H82J35BABCA													
2	COMP-BZP16-001	ZP16K5EPFV130	X												
2	COMP-BZP24-001	ZP24K5EPFV130		X											
2	COMP-BZP28-001	ZP28K5EPFV130			X										
2	COMP-BZP28-003	ZP28K5ETFD130				X									
2	COMP-BZP34-001	ZP34K5EPFV130					X								
2	COMP-BZP34-003	ZP34K5ETFD130						X							
2	COMP-BZP34-004	ZP34K5ETFD130							X						
2	COMP-BZP44-001	ZP44K5EPFV130							X						
2	COMP-BZP44-003	ZP44K5ETFD130								X					
2	COMP-BZP44-004	ZP44K5ETFD130									X				
2	COMP-BZP54-001	ZP57K5EPFV130										X			
2	COMP-BZP54-003	ZP57K5ETFD130											X		
2	COMP-BZP54-004	ZP57K5ETFD130												X	
7	COND-V424	COND COIL	X	X											
7	COND-V436	COND COIL			X	X	X	X	X						
7	COND-V460	COND COIL								X	X	X	X	X	X
8	550510	FLOWRATOR 4 CIRCUIT-COND	X												
8	550505	FLOWRATOR 3 CIRCUIT-COND		X	X	X	X	X	X						
8	550517	FLOWRATOR 6 CIRCUIT-COND								X	X	X	X	X	X
14	EVAP-VH424	EVAP COIL	X	X											
14	EVAP-VH436	EVAP COIL			X	X	X	X	X						
14	EVAP-VH460	EVAP COIL								X	X	X	X	X	X
15	550510	FLOWRATOR 4 CIRCUIT-EVAP	X												
15	550517	FLOWRATOR 6 CIRCUIT-EVAP		X	X	X	X	X	X						
15	550521	FLOWRATOR 9 CIRCUIT-EVAP								X	X	X	X	X	X
	550536	RESTRICTOR .063	X	X											
	550531	RESTRICTOR .065			X	X									
	550538	RESTRICTOR .070					X	X	X						
	550550	RESTRICTOR .094								X	X	X			
	550548	RESTRICTOR .096											X	X	X
	061507	FILTER DRIER	X	X	X	X	X	X	X						
	061508	FILTER DRIER								X	X	X	X	X	X
3	2021-5008	FAN SHROUD V18-24	X	X											
3	2022-5008	FAN SHROUD V30-36			X	X	X	X	X						
3	2023-5008	FAN SHROUD V48-60								X	X	X	X	X	X
4	259108	MOTOR MOUNT CONDENSER FAN	X	X	X	X	X	X	X						
4	259109	MOTOR MOUNT CONDENSER FAN								X	X	X	X	X	X
5	0250-0025	MOTOR CONDENSER 230V 1/5 HP	X	X	X	X	X	X							
5	351145	MOTOR CONDENSER 230V 1/2 HP								X	X		X	X	
5	359100	MOTOR CONDENSER 460V 1/4 HP							X						
5	351146	MOTOR CONDENSER 460V 1/2 HP										X			X
6	0550-0009	FAN BLADE 20" V18-36	X	X	X	X	X	X	X						
6	259114	FAN BLADE 22" V48-60								X	X	X	X	X	X
9	2022-5000	ASSEMBLY LEFT SIDE PANEL V18-36	X	X	X	X	X	X	X						
9	2023-5000	ASSEMBLY LEFT SIDE PANEL V48-60								X	X	X	X	X	X
10	2021-5012	ASSEMBLY REAR PANEL V18-24	X	X											
10	2022-5012	ASSEMBLY REAR PANEL V30-36			X	X	X	X	X						
10	2023-5012	ASSEMBLY REAR PANEL V48-60								X	X	X	X	X	X
11	2021-5003	ASSEMBLY DIVIDER DECK V18-24	X	X											
11	2022-5003	ASSEMBLY DIVIDER DECK V30-36			X	X	X	X	X						
11	2023-5003	ASSEMBLY DIVIDER DECK V48-60								X	X	X	X	X	X
12	2021-5005	ASSEMBLY BLOWER PAN V18-24	X	X											
12	2022-5005	ASSEMBLY BLOWER PAN V30-36			X	X	X	X	X						
12	2023-5005	ASSEMBLY BLOWER PAN V48-60								X	X	X	X	X	X
13	2021-0006P	ASSEMBLY DRAIN PAN V18-24	X	X											
13	2022-0006P	ASSEMBLY DRAIN PAN V30-36			X	X	X	X	X						
13	2023-5006	ASSEMBLY DRAIN PAN V48-60								X	X	X	X	X	X
17	2021-5002	BASE PAN ASSEMBLY V18-24	X	X											
17	2022-5002	BASE PAN ASSEMBLY V30-36			X	X	X	X	X						
17	2023-5002H	BASE PAN ASSEMBLY V48-40								X	X	X	X	X	X
22	2021-5018	BLOWER MNTG TRAY V18-24	X	X											
22	2022-5018	BLOWER MNTG TRAY V30-36			X	X	X	X	X						
22	2023-5018-4	BLOWER MNTG TRAY V48								X	X	X			
22	2023-5018-5	BLOWER MNTG TRAY V60											X	X	X
23	2022-5001	ASSEMBLY RIGHT SIDE V18-36	X	X	X	X	X	X	X						
23A	2023-5001	ASSEMBLY RIGHT SIDE V48-60								X	X	X	X	X	X
23A	2023-5088	GRILL INLET RIGHT SIDE V48-60								X	X	X	X	X	X
23B	2023-5089	GRILL INLET LEFT SIDE V48-60								X	X	X	X	X	X
24	194700050002	BLOWER 9-7R DD 18, 24, & 48 CW RIGHT	X	X						X	X	X			
24	194700050004	BLOWER 10-7R DD 60 CW RIGHT											X	X	X
24	0500-0010	BLOWER 10-10 DD 30 & 36			X	X	X	X	X						
24A	194700050001	BLOWER 9-7L DD 48 CCW LEFT								X	X	X			
24A	194700050003	BLOWER 10-7L DD 60 CCW LEFT											X	X	X
25	351115	MOTOR BLOWER 1/6 HP 230V	X	X											
25	194090000006	MOTOR BLOWER 1/3 HP 230V			X	X	X	X							
25	020008	MOTOR BLOWER 1/2 HP double shaft 230V								X	X				
25	351424	MOTOR BLOWER 3/4 HP double shaft 230V											X	X	
25	359101	MOTOR BLOWER 1/3 HP 460V (2-3 ton)							X						
25	020005	MOTOR BLOWER 1/2 HP double shaft 460V										X			
25	351426	MOTOR BLOWER 3/4 HP double shaft 460V													X
26	BLWR-MTG2B	MOTOR MOUNT INDOOR ASSY V18-24	X	X											
26	258972	MOTOR MOUNT INDOOR ASSY V30-36			X	X	X	X	X						
26	258976	MOTOR MOUNT INDOOR ASSY V48-60								X	X	X	X	X	X
27	2021-5007	TOP V18-24	X	X											
27	2022-5007	TOP V30-36			X	X	X	X	X						
27	2023-5007	TOP V48-60								X	X	X	X	X	X

REPLACEMENT PARTS LIST - V SERIES WALLMOUNT A/C

28	2021-5010	TOP FRONT PANEL V18-24	X	X													
28	2022-5010	TOP FRONT PANEL V30-36			X	X	X	X	X								
28	2023-5010	TOP FRONT PANEL V48-60								X	X	X	X	X	X	X	
29	2021-5011	MIDDLE FRONT PANEL (no fresh air) V18-24	X	X													
29	2021-5011E	MIDDLE FRONT PANEL (economizer f/a) V18-24	X	X													
29	2021-5011F	MIDDLE FRONT PANEL (barometric f/a) V18-24	X	X													
29	2022-5011	MIDDLE FRONT PANEL (no fresh air) V30-36			X	X	X	X	X								
29	2022-5011E	MIDDLE FRONT PANEL (economizer f/a) V30-36			X	X	X	X	X								
29	2022-5011F	MIDDLE FRONT PANEL (barometric f/a) V30-36			X	X	X	X	X								
29	2023-5011	MIDDLE FRONT PANEL (no fresh air) V48-60								X	X	X	X	X	X	X	
29	2023-5011E	MIDDLE FRONT PANEL (economizer f/a) V48-60								X	X	X	X	X	X	X	
29	2023-5011F	MIDDLE FRONT PANEL (barometric f/a) V48-60								X	X	X	X	X	X	X	
30	2021-5014	LOWER CONDENSER PANEL V18-24	X	X													
30	2022-5014	LOWER CONDENSER PANEL V30-36			X	X	X	X	X								
30	2023-5014	LOWER CONDENSER PANEL V48-60								X	X	X	X	X	X	X	
31	2022-5062	DISCONNECT ACCESS DOOR V18-60	X	X	X	X	X	X	X	X	X	X	X	X	X	X	
31A	070518	BREAKER DOOR LATCH V18-60	X	X	X	X	X	X	X	X	X	X	X	X	X	X	
32	659942	AIR FILTER DISPOSABLE 16x25x1 V18-36	X	X	X	X	X	X	X								
32	659943	AIR FILTER DISPOSABLE 16x25x2 V18-36	X	X	X	X	X	X	X								
32	659926	AIR FILTER DISPOSABLE 20x30x1 V48-60								X	X	X	X	X	X	X	
32	659924	AIR FILTER DISPOSABLE 20x30x2 V48-60								X	X	X	X	X	X	X	
	654602	ALUMINUM FILTER 5x30x.025 V18-60	X	X	X	X	X	X	X	X	X	X	X	X	X	X	
34	2021-5004	FILTER RACK V18-24	X	X													
34	2022-5004	FILTER RACK V30-36			X	X	X	X	X								
34	2023-5004	FILTER RACK V48-60								X	X	X	X	X	X	X	
35	2022-5021	HEATER MOUNTING PLATE V18-36	X	X	X	X	X	X	X								
35	65S1007-F	HEATER MOUNTING PLATE V48-60								X	X	X	X	X	X	X	
36	EGA05B1-AC	FIELD INSTALL HEAT KIT 5KW 1 PHASE 230V	X	X	X		X			X				X			
36	0430-0074	HEATER 5KW 1P 240V	X	X	X		X			X				X			
36	EGA10B1-AC	FIELD INSTALL HEAT KIT 10KW 1 PHASE 230V	X	X	X		X			X				X			
36	0430-0072	HEATER 10KW 1P 240V	X	X	X		X			X				X			
36	EGH15B1-AC	FIELD INSTALL HEAT KIT 15KW 1 PHASE 230V	X	X	X		X			X				X			
36	0430-0074	HEATER 5KW 1P 240V					X			X				X			
36	0430-0072	HEATER 10KW 1P 240V					X			X				X			
36	EGH06B3-AC	FIELD INSTALL HEAT KIT 6KW 3 PHASE 230V					X			X				X			
36	458009	HEATER 6KW 3P 240V					X			X				X			
36	EGH11B3-AC	FIELD INSTALL HEAT KIT 11KW 3 PHASE 230V					X			X				X			
36	458011	HEATER 11KW 3P 240V					X			X				X			
36	EGH18B3-AC	FIELD INSTALL HEAT KIT 18KW 3 PHASE 230V					X			X				X			
36	458013	HEATER 18KW 3P 240V								X				X			
36	EGH06D4-AC	FIELD INSTALL HEAT KIT 6KW 3 PHASE 460V								X				X			
36	458015	HEATER 6KW 3P 460V								X				X			
36	EGH11D4-AC	FIELD INSTALL HEAT KIT 11KW 3 PHASE 460V								X				X			
36	458017	HEATER 11KW 3P 460V								X				X			
36	EGH15D4-AC	FIELD INSTALL HEAT KIT 15KW 3 PHASE 460V								X				X			
36	458020	HEATER 15KW 3P 460V								X				X			
37	2022-HEPL	HEATER EXTENSION PLATE H24-36	X	X	X	X	X	X	X								
37	2023-HEPL	HEATER EXTENSION PLATE H48-60								X	X	X	X	X	X	X	
38	454332	SWITCH LIMIT 245F ONE SHOT	X	X	X	X	X	X	X	X	X	X	X	X	X	X	
38	454323	SWITCH LIMIT 160-30F 240 W/FUSE	X	X	X	X	X	X	X	X	X	X	X	X	X	X	
39	2021-5009H	BOX CONTROL V18-24	X	X													
39	2022-5009H	BOX CONTROL V30-36			X	X	X	X	X								
39	2023-5009H	BOX CONTROL V48-60								X	X	X	X	X	X	X	
40	2021-5017	COMPRESSOR ACCESS DOOR V18-24	X	X													
40	2022-5017	COMPRESSOR ACCESS DOOR V30-36			X	X	X	X	X								
40	2023-5017	COMPRESSOR ACCESS DOOR V48-60								X	X	X	X	X	X	X	
41	2021-5020	BLOWER CUT OFF SHIELD V18-24	X	X													
41	2022-5020	BLOWER CUT OFF SHIELD V30-36			X	X	X	X	X								
41	2023-5020-4	BLOWER CUT OFF SHIELD V48								X	X	X					
41	2023-5020-5	BLOWER CUT OFF SHIELD V60												X	X	X	
42	2022-0015	PLATE TOP INSUL PROTECT HV30-36	X	X	X	X	X	X	X	X	X	X	X	X	X	X	

ELECTRICAL COMPONENTS PARTS LIST

	453150	COMP CONTACTOR 1 POLE 1P 25 AMP	X	X	X		X			X							
	453770	COMP CONTACTOR 2 POLE 1P 40 AMP												X			
	453772	COMP CONTACTOR 3 POLE 3P 25 AMP				X		X	X	X	X	X			X	X	
	452842	PHASE MONITOR				X		X	X	X	X	X			X	X	
	450362	COMP CAPACITOR 7.5/35@370															
	0400-0031	COMP CAPACITOR 10/80@370												X			
	450368	COMP CAPACITOR 7.5/40@370			X												
	450364	COMP CAPACITOR 7.5/40@440															
	450361	COMP CAPACITOR 7.5/30@370	X														
	450370	COMP CAPACITOR 7.5/45@370			X		X										
	450378	COMP CAPACITOR 10/70@370								X							
	450325	BLWR CAPACITOR 10@370										X					X
	450205	BLWR CAPACITOR 7.5@370	X	X						X	X	X		X	X		
	160500730145	BLWR CAPACITOR 7.5@440			X	X	X	X	X								
	451000	TERMINAL BLOCK	X	X	X	X	X	X	X	X	X	X	X	X	X	X	
	452752	TRANSFORMER 208/240V 50VA 24V	X	X	X	X	X	X	X	X	X	X	X	X	X	X	
	452756	TRANSFORMER 480V 50VA 24V								X			X				X
	452200	FAN RELAY	X	X	X	X	X	X	X	X	X	X	X	X	X	X	
	0821N-0084A	FAN RELAY								X			X				X
	042004	CIRCUIT BREAKER 2 POLE 1P 60 AMP 240V	X	X	X		X			X			X				
	453807	CIRCUIT BREAKER 3 POLE 3P 60 AMP				X		X			X				X		
	451955	DISCONNECT KIT 460V								X			X				X
	451956	DISCONNECT KNOB 460V								X			X				X
	0415-0028	LOW VOLTAGE TERMINAL BOARD	X	X	X	X	X	X	X	X	X	X	X	X	X	X	
	451049	JUMPER BAR ASSEMBLY															OPTIONAL
	451840	OPTION BOARD															OPTIONAL
	454388	LOW PRESSURE SWITCH															OPTIONAL
	451988	HIGH PRESSURE SWITCH															OPTIONAL
	451992	FAN CYCLE SWITCH															OPTIONAL

*Part Numbers are Subject to Change

V Series Air Conditioners Electrical Data

MODEL NO. & ELECTRIC HEATER KW [1]	VOLT/PHASE	NO. OF FIELD POWER CKTS.	SINGLE-FIELD CIRCUIT				DUAL-FIELD CIRCUIT												
			MIN. CIRCUIT AMPACITY	MAX. OVER CURRENT PROTECTION [2]	FIELD POWER WIRE SIZE [3], [4], [5]	GROUND WIRE SIZE	MIN. CIRCUIT AMPACITY		MAX. OVER CURRENT PROTECTION [2]		FIELD POWER WIRE SIZE [3], [4], [5]		GROUND WIRE SIZE						
							CKT1	CKT2	CKT1	CKT2	CKT1	CKT2	CKT1	CKT2					
V418B00A1 5 10	208-230/1	1	16	30	14	14													
		1	28	30	10	10													
		1	54	60	6	10													
V424B00A1 5 10	208-230/1	1	18	30	14	14													
		1	28	30	10	10													
		1	54	60	6	10													
V424B00A3 6 11	208-230/3	1	15	30	14	14													
		1	20	30	14	14													
		1	35	60	10	10													
V430B00A1 5 10 15	208-230/1	1	24	30	12	12													
		1	29	30	10	10													
		1	55	60	6	10													
		1 OR 2	81	90	4	8	29	52	30	60	10	6	10	10					
V436B00A1 5 10 15	208-230/1	1	26	30	12	12													
		1	29	30	10	10													
		1	55	60	6	10													
		1 OR 2	81	90	4	8	26	52	30	60	10	6	10	10					
V436B00A3 6 11 15	208-230/3	1	20	30	12	12													
		1	21	30	12	12													
		1	36	60	8	10													
		1	48	60	8	10													
V436B00A4 6 11 15	460/3	1	9	15	14	14													
		1	10	15	14	14													
		1	17	30	14	14													
		1	23	30	12	12													
V448B00A1 5 10 15 20	208-230/1	1	32	60	10	10													
		1	32	60	10	10													
		1	55	60	6	10													
		1 OR 2	81	90	4	8	29	52	30	60	10	6	10	10					
		1 OR 2	107	125	2	6	55	52	60	60	6	6	10	10					
V448B00A3 6 11 15 18	208-230/3	1	24	30	12	12													
		1	24	30	12	12													
		1	36	60	8	10													
		1	48	60	8	10													
		1	57	60	6	10													
V448B00A4 6 11 15	460/3	1	12	15	14	14													
		1	12	15	14	14													
		1	19	30	14	14													
		1	25	30	10	10													
V460B00A1 5 10 15 20	208-230/1	1	44	60	8	10													
		1	44	60	8	10													
		1	57	60	6	10													
		1 OR 2	83	90	4	8	31	52	60	60	10	6	10	10					
		1 OR 2	109	125	2	6	57	52	60	60	6	6	10	10					
V460B00A3 6 11 15 18	208-230/3	1	32	60	10	10													
		1	32	60	10	10													
		1	38	60	8	10													
		1	50	60	6	10													
		1	59	60	6	10													
V460B00A4 6 11 15	460/3	1	15	30	14	14													
		1	15	30	14	14													
		1	19	30	14	14													
		1	25	30	10	10													
V460B00A1 5 10 15 20	208-230/1	1	41	60	8	10													
		1	41	60	8	10													
		1	57	60	6	10													
		1 OR 2	83	90	4	8	31	52	60	60	10	6	10	10					
		1 OR 2	109	125	2	6	57	52	60	60	6	6	10	10					
V460B00A3 6 11 15 18	208-230/3	1	29	30	10	10													
		1	29	30	10	10													
		1	38	60	8	10													
		1	50	60	6	10													
		1	59	60	6	10													
V460B00A4 6 11 15	460/3	1	15	15	14	14													
		1	15	15	14	14													
		1	19	30	14	14													
		1	25	30	10	10													

[1] Heater data were based on 240V or 480V AC respectively.
 [2] Maximum recommended size for "Time Delay" fuse or HACR circuit breaker.
 [3] Power supply wire size and ground wire size were based on AWG 75C rise, NEC Article 310 and Table 310-16.
 [4] For single power conductor, sized per NEC Table 310-16.
 [5] Power supply wire minimum 75°C rated COPPER CONDUCTOR ONLY.

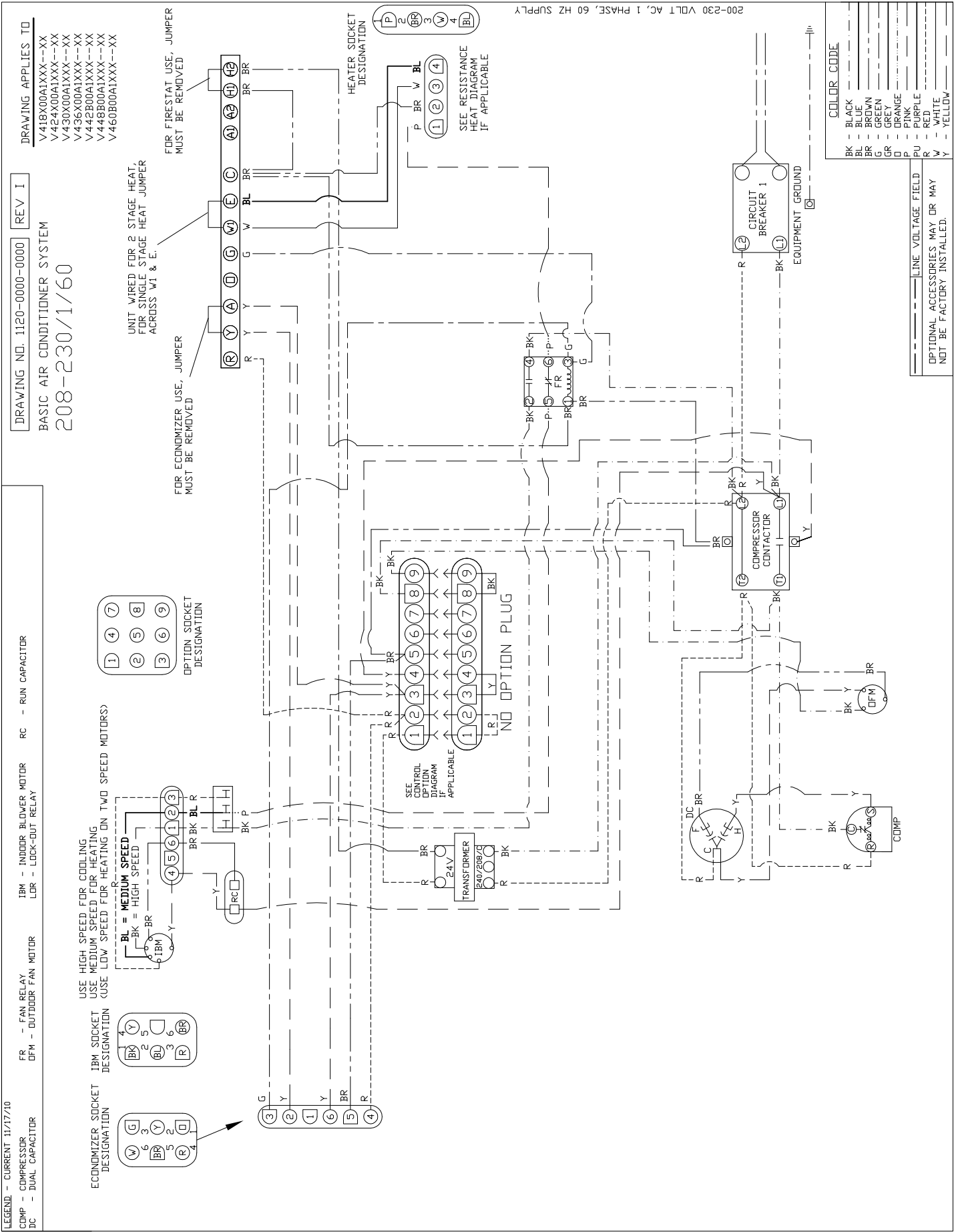

LEGEND - CURRENT 11/17/10
 COMP - COMPRESSOR
 DC - DUAL CAPACITOR

DFM - OUTDOOR FAN MOTOR
 FR - FAN RELAY

IBM - INDOOR BLOWER MOTOR
 PM - PHASE MONITOR

IBM - INDOOR BLOWER MOTOR
 RC - RUN CAPACITOR

DRAWING NO. 1120-0011-0000
 REV H
 BASIC AIR CONDITIONER SYSTEM
 460/3/60

DRAWING APPLIES TO
 V424B00A4XXX--XX
 V430B00A4XXX--XX
 V436B00A4XXX--XX
 V442B00A4XXX--XX
 V448B00A4XXX--XX
 V460B00A4XXX--XX

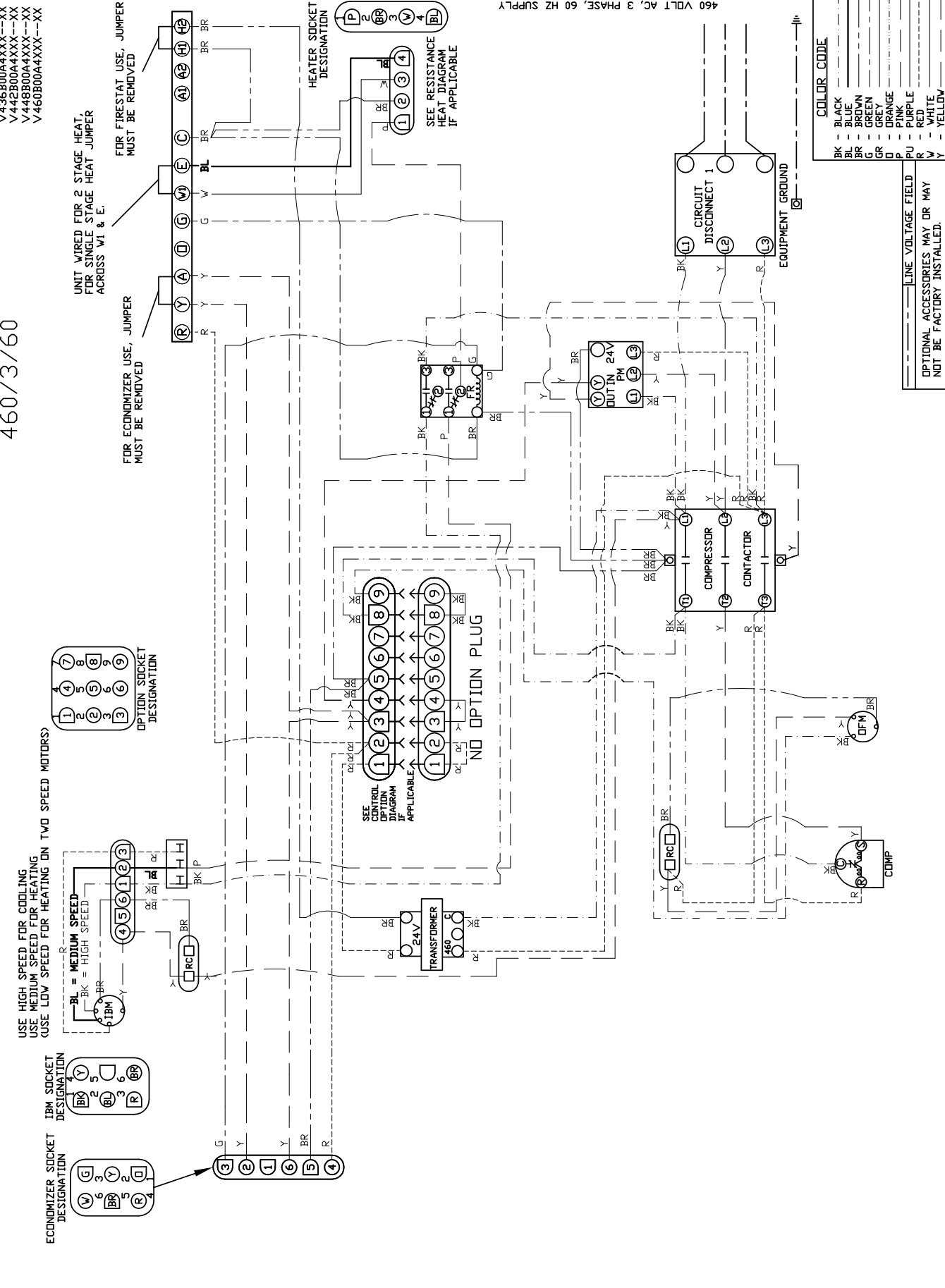

UNIT DIMENSIONS (INCHES)

MODEL	A	B	C	D	E	F	G	H	I	J	K	L	M	N	P	Q	R	S	T	U	V	W	X	Y	Z
18/24	36	34	18 ⁵ / ₈	28 ¹ / ₁₆	12	20 ¹ / ₂	8	1 ⁷ / ₈	20	28 ⁹ / ₁₆	1 ¹ / ₈	71 ¹ / ₂	2 ¹ / ₂	10 ¹ / ₂	18 ¹ / ₂	26 ¹ / ₂	34 ⁷ / ₈	1 ¹ / ₈	16	32	1 ¹⁵ / ₁₆	2 ⁹ / ₁₆	29 ¹ / ₂	27 ¹ / ₈	27 ⁵ / ₈
30/36	40	38	18 ⁵ / ₈	28 ¹ / ₂	14	18	8	1 ⁷ / ₈	28	28 ⁹ / ₁₆	1 ¹ / ₈	71 ¹ / ₂	2 ¹ / ₂	10 ¹ / ₂	18 ¹ / ₂	26 ¹ / ₂	39	1 ¹ / ₄	18 ¹ / ₄	36 ³ / ₈	2	2 ⁹ / ₁₆	29 ¹ / ₂	27 ¹ / ₈	31 ⁵ / ₈
48/60	43 ¹ / ₈	41	24	27 ¹ / ₂	16	30	10	2 ¹ / ₄	30	36 ¹ / ₂	1 ¹ / ₈	87	2 ¹ / ₂	10 ¹ / ₂	18 ¹ / ₂	26 ¹ / ₂	42	1 ¹ / ₈	19 ³ / ₄	39 ¹ / ₂	6 ¹ / ₂	3 ³ / ₄	29 ¹ / ₂	27 ¹ / ₈	33 ¹ / ₂

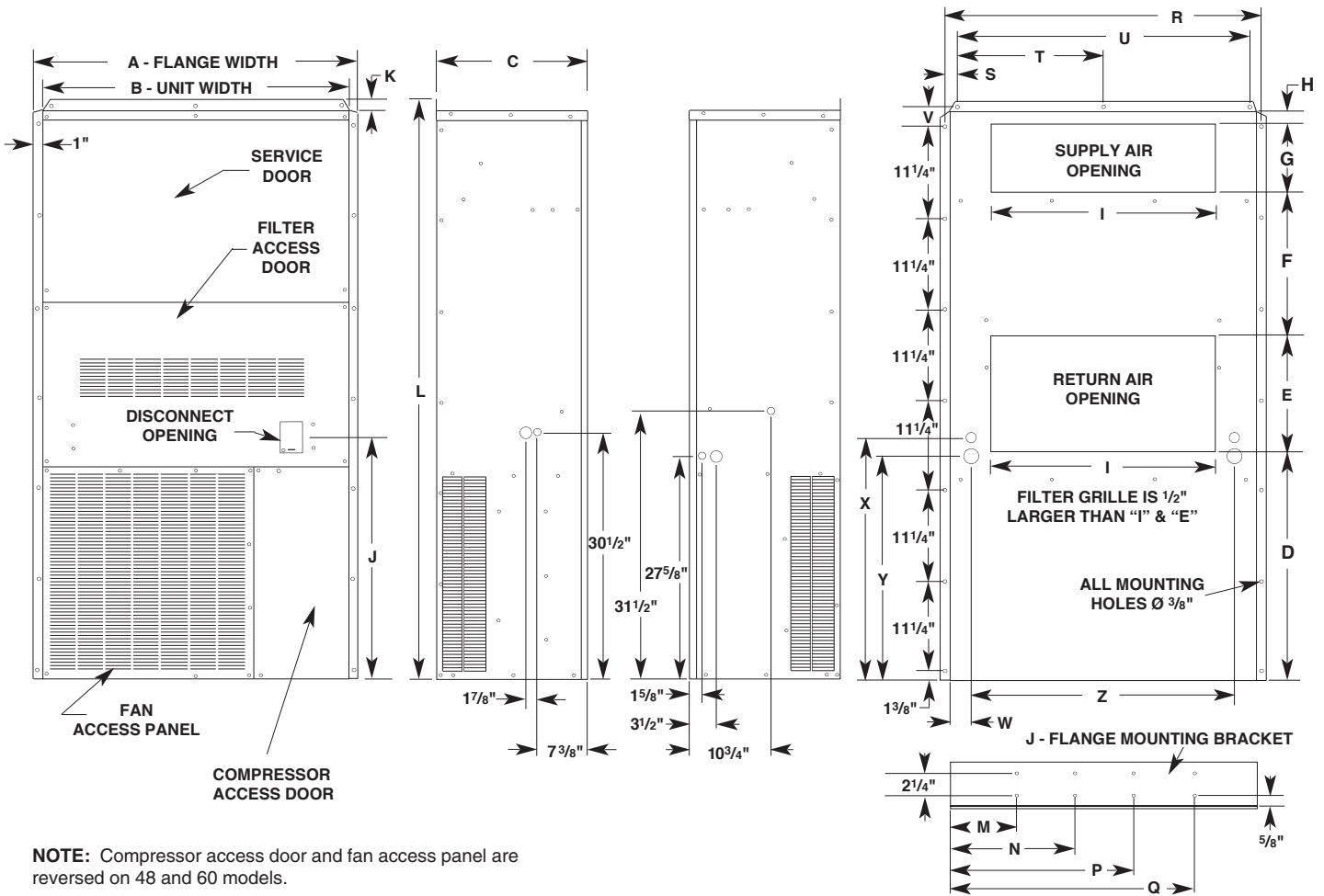

RATED INDOOR AIR FLOW RATE

SIZE	18	24	30	36	48	60
CFM	670	800	1250	1250	1800	2100



The information in this manual supersedes and replaces the previous instruction/operation manual 678629-V with regards to V Series wallmount products. Illustrations, part numbers and others cover the general appearance of the units at the time of publication and the manufacturer reserves the right to make changes in design and construction at any time without notice.

For replacement parts contact:
National Coil Company
1998 FM 2011
Longview, TX 75603
Phone: 903-643-2261
Fax: 903-643-2222